

**King Mongkut's University of Technology Thonburi**

Mid-term Examination  
Semester 1 Academic Year 2018

**CVE 233: Mechanics of Materials**

**International Program in Civil Engineering**  
**International Program in Environmental Engineering**

Date: 3<sup>rd</sup> October 2018

Time: 13:00 – 16:00

**Instructions:**

1. There are 4 questions in this examination with unequal marks.
2. This examination paper consists of 5 pages (including this one).
3. The last page of this examination paper contains equations you may find useful.
4. Read each question carefully, disobedience of instruction will result in 0 mark.
5. Make sure that your answers are marked in **distinguishable** way.
6. Answer in separate answer books.
7. No textbooks and written materials are allowed in the examination room.
8. Calculator is allowed.
9. Student are not allowed to take examination scripts, answer booklets or any materials out of the examination room. Violation of the rule shall result in a penalty of student receiving zero in that examination
10. Student who are caught cheating in the examination shall be penalized by receiving Fail grade (F) in that subject and is forced to withdraw (W) from all remaining subjects in that semester. The maximum penalty may include expulsion

**Examiner:** Dr. Julapot Chiravachradej  
Tel. 02-470-9307  
081-401-2339

This examination paper has been approved by the Department of Civil Engineering

A handwritten signature in black ink, appearing to read 'Sutata Leelataviwat', written over a horizontal line.

Assoc. Professor Dr. Sutata Leelataviwat  
Head of the Civil Engineering Department

1. The column depicted below is loaded by a single uniformly-distributed load which covers the column's whole height. The resulting shear force and bending moment diagrams are also shown next to the column geometry while the choices cross section area alignments on the top. The cross-section area, which is consistent throughout the column, is a composite material made of steel and wood. The steel plates are bolted to the wood to ensure coherent cross-sectional behavior using 4 bolts (the 4 thick vertical line) at connecting point with a constant spacing of 20 cm. If the modulus of elasticity of steel is  $2 \times 10^6 \text{ N/mm}^2$  while that of wood is  $0.2 \times 10^6 \text{ N/mm}^2$ , determine (total of 120 marks)
- With the effects of bending moment in mind, choose the most suitable cross-section area alignment below and state clear reasons for your choice. (20 marks)
  - Maximum tensile and compressive axial stresses caused by bending moment in both materials and their positions. (40 marks)
  - Maximum transverse shear stresses in both materials and their positions. (40 marks)
  - The minimum required strength of the nails. (20 marks)

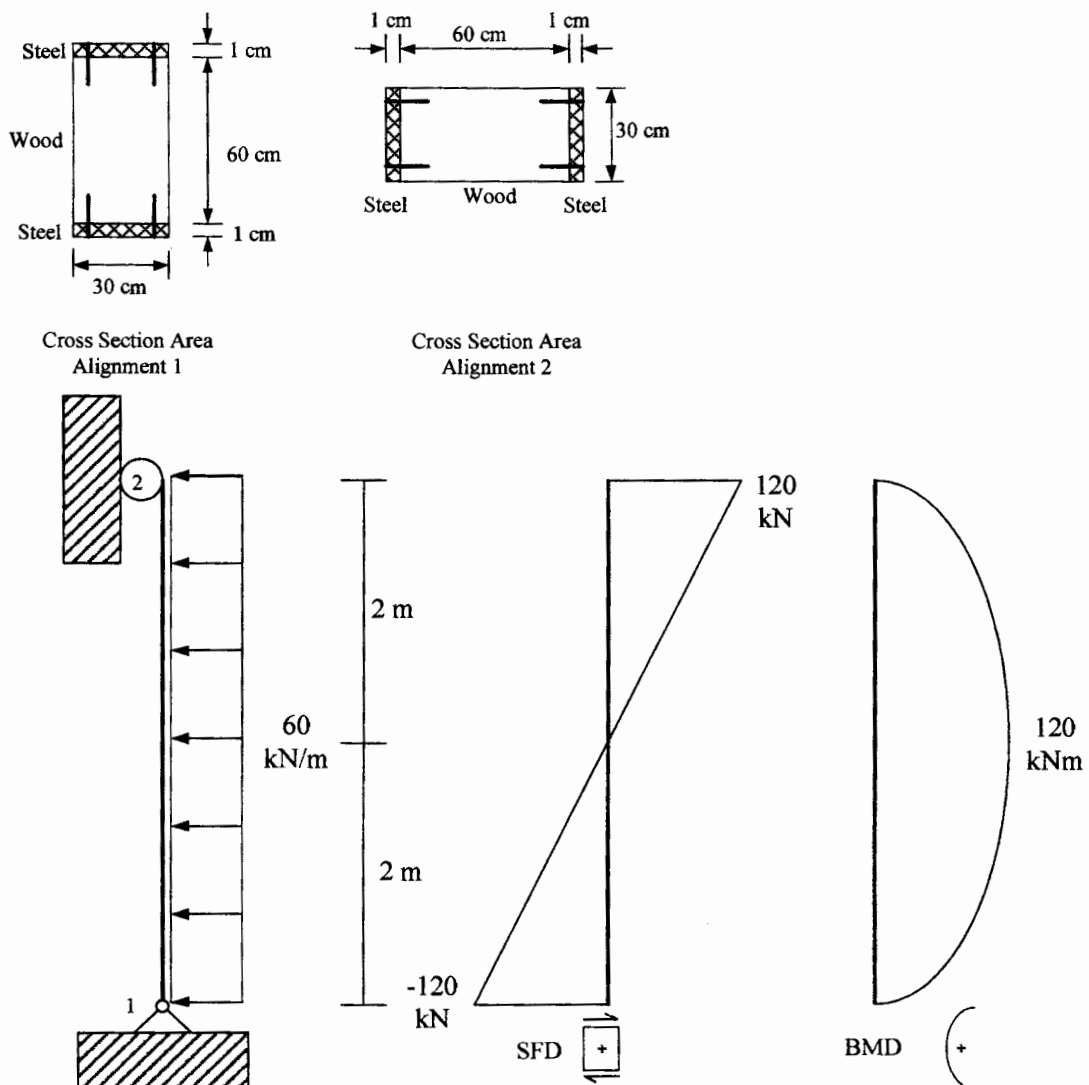
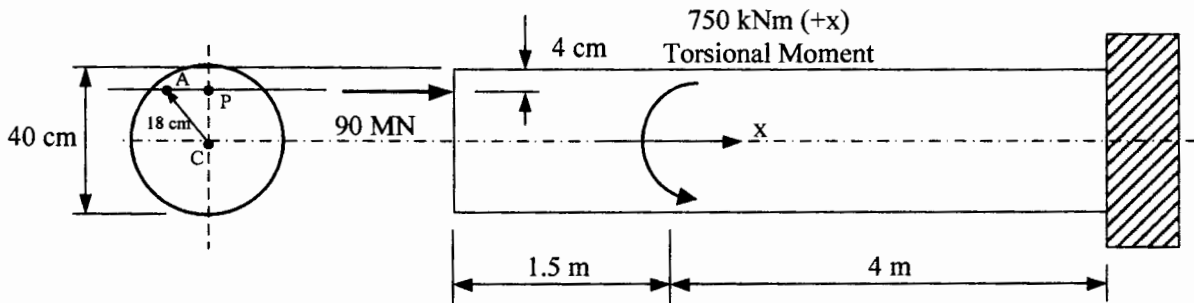

**Figure 1: Composite-Material Column resisting bending moment and shear force**

2. The beam illustrated below is subjected to an off-centroid loading of 90 MN (acting at point P on the cross-section area) and a torsional moment of 750 kNm. Assume that the weight of the beam is negligible and for this cross section, determine (total of 120 marks)

Hint: It could be less complicated if you use superposition concept to separately solve off-centroid loading and torsion cases.

- The maximum combined tensile and compressive axial stresses. (40 marks)
- The maximum shear stress caused by torsion (20 marks)
- The axial and shear stresses at point A, which is at the same height as point P. (40 marks)
- The angle of twist at the free end if shear modulus of this material is  $79.3 \times 10^9 \text{ N/m}^2$ . (20 marks)



**Figure 2: A beam subjected to off-centroid loading and torsional moment**

3. Consider 2 columns with exactly the same geometrical features, i.e., same circular cross-sectional area, same material, etc., and 2 fixed supports each. If one is subjected to a force inducing pure axial forces whereas the other pure torsional moments, discuss the similarity and differences between the 2 cases based on behaviors and parameters related to mechanics. (30 marks)

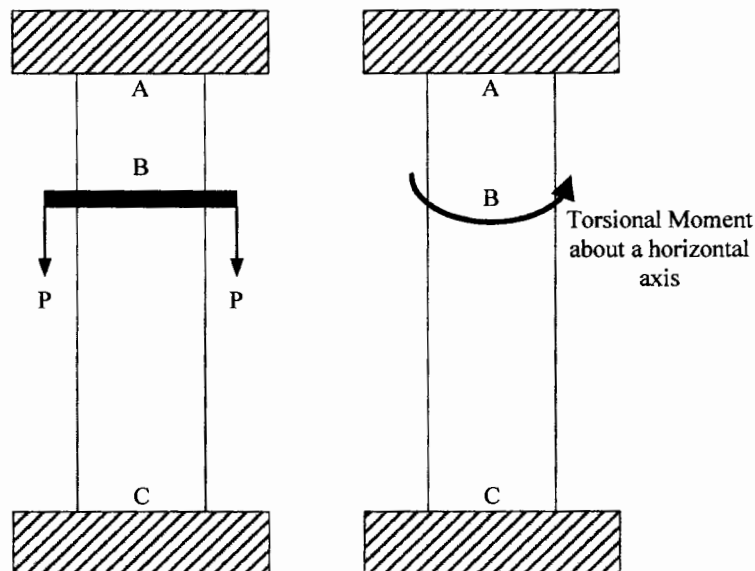

**Figure 3: 2 identical columns subjected to different applied loadings**

4. The pictures in Figure 4's illustrate the concept from the beam subjected to pure bending moment to resulting stress pattern and arbitrary cross-sectional area. Prove that  $\sigma = \frac{(BM)}{I} y$ . (30 marks)

Note that if you would like to prove this some other way, please feel free to do so.

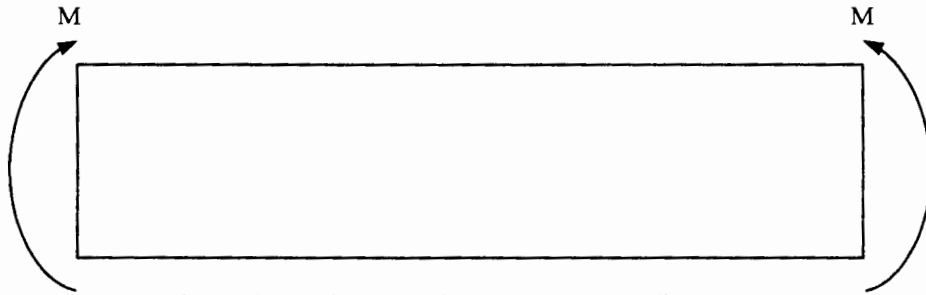

Figure 4-1: A beam subjected to pure bending moment

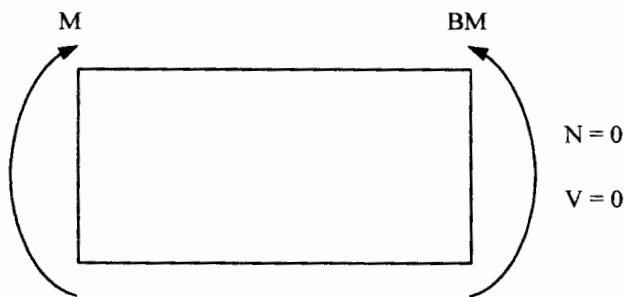

Figure 4-2: FBD showing consistent bending moment

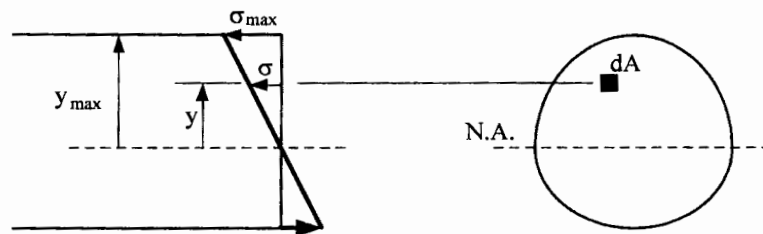

Figure 4-3: Stress pattern caused by bending moment and cross sectional area

## Given Equations

- **Stress and Deformation caused by Axial Force**

$$\sigma = \frac{N}{A} \quad \text{and} \quad \Delta = \frac{NL}{EA}$$

- **Stress caused by Bending Moment**

$$\sigma = \frac{(BM)y}{I}$$

- **Area Moment of Inertia**

For Rectangle with axis through centroid and perpendicular to H:  $I = (BH^3) / 12$

For Circle with axis through centroid:  $I = \pi r^4 / 4$

Parallel-axis Theorem:  $I' = I + Ad^2$

- **Area and Stress Transformation for Composite Materials**

Changing Material A to Material B

$$n = \frac{E_A}{E_B} \quad \text{and} \quad \sigma_A = n\sigma'_A$$

- **Stress caused by Shear Force**

$$\tau = \frac{VQ}{It}$$

- **1<sup>st</sup> Moment of Area**

$$Q = A'\bar{y}'$$

- **Shear Flow for Built-up Cross Section**

$$q = \frac{VQ}{I}$$

- **Stress and Deformation by Torsion**

$$\tau = \frac{Tr}{J} \quad \text{and} \quad \phi = \frac{TL}{JG}$$

- **Stress and Deformation by Torsion for Rectangle Cross Section**

$$\tau_{\max} = \frac{T}{C_1 ab^2} \quad \text{and} \quad \phi = \frac{TL}{C_2 ab^3 G}, \quad \text{where } a \text{ is the wider side and } b \text{ the narrower}$$

- **Polar Area Moment of Inertia**

General Cases:  $J = I_x + I_y$

For a circle with polar axis at the center of the circle:  $J = \frac{\pi r^4}{2}$