



King Mongkut's University of Technology Thonburi
Midterm Examination

Semester 1 Academic Year 2018

CVE 232 Engineering Mechanics II

2nd Year International Program

Date of Examination: Thursday, 4th October, 2018

Time: 13.00-16.00.

Instruction:

1. There are 9 questions. Total score of this exam is 40 marks. Attempt all questions.
2. This exam consists of 9 pages (including this page).
3. **Textbooks and written materials are not allowed** in the examination room.
4. **A calculator is allowed** in the examination room.
5. Write your name and student ID on each page.
6. The answers must be **written in ENGLISH.**

Examiners : Asst.Prof.Dr. ChainarongAthisakul

Tel. 02-470-9143

Student Name: _____ **I.D.Number** _____ **Seat Number** _____

This examination paper has been approved by the Department of Civil Engineering

(Assoc.Prof. Dr. SutatLeelataviwat)
 Head of the Civil Engineering Department

1. The acceleration of a particle traveling along a straight line is $a = \frac{10}{v} \text{ m/s}^2$. Given $s = 0$, $v = 20 \text{ m/s}$ when $t = 0 \text{ s}$, determine the velocity of the particle as a function of time. (3 marks)

2. A 1.5 kg ball strikes the rough ground and rebounds with the velocities shown. Determine the magnitude of impulsive force exerted on the ball. Neglect the impulse produced by the ball's weight. (3 marks)

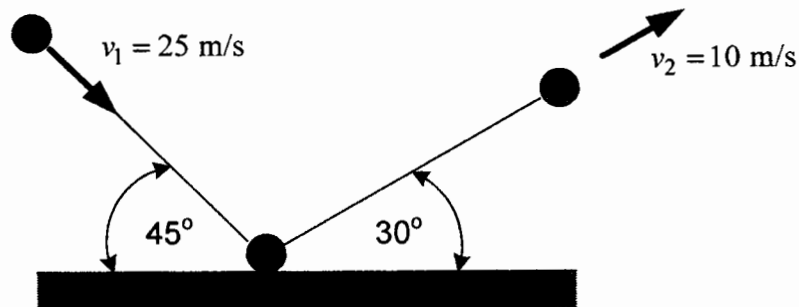

Student Name: _____ I.D. Number _____ Seat Number _____

3. A car is traveling at 20 m/s, when the traffic light 40 m ahead turns yellow. Determine the required constant deceleration of the car and the time needed to stop the car at the light. (3 marks)

4. At a given instant, a car travels along a circular curved road with a speed of 20 m/s while decreasing its speed at the rate of 4 m/s^2 . If the magnitude of the car's acceleration is 5 m/s^2 , determine the radius of curvature of the road. (3 marks)

5. The a - s graph for a car traveling along a straight road is given for the first 300 m of its motion. Construct the v - s graph. The initial condition is given by $s = 0, v = 0$. (5 marks)

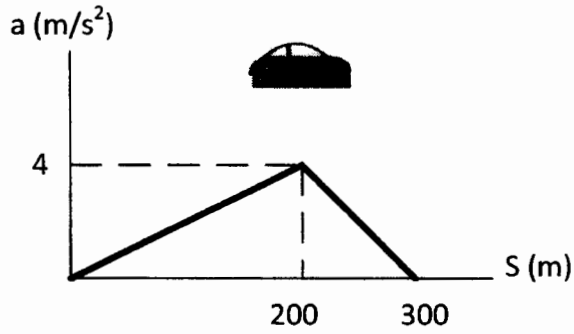

Student Name: _____ I.D. Number _____ Seat Number _____

6. A particle travels along the circular path $x^2 + y^2 = r^2$. If the y component of the particle's velocity is $v_y = 2r \cos 4t$, determine the x and y components of its acceleration at any instant. (5 marks)

7. At the instant shown, point P on the cable has a velocity $v_p = 12 \text{ m/s}$, which is increasing at a rate of $a_p = 6 \text{ m/s}^2$. Determine the power input of motor M at this instant if it operates with an efficiency $\varepsilon = 0.8$. The mass of block A is 60 kg. (5 marks)

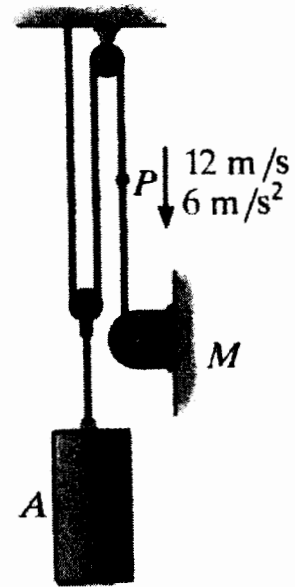

8. The fireman wishes to direct the flow of water from his hose to the fire at B. Determine two possible angles θ_1 and θ_2 at which this can be done. Water flows from the hose at $v_A = 90$ ft/s
(Hint: θ_1 is applied for shooting down, θ_2 is applied for shooting up, the nonlinear equation can be solved by trial and error method)
(6 marks)

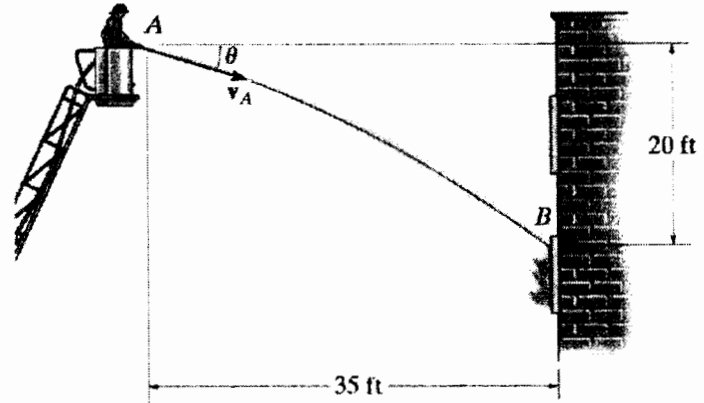

9. A 10 kg block A is released from rest 2 m above the 5 kg plate P, which can slide freely along the smooth vertical guides BC and DE. Determine the velocity of the block and plate just after impact. The coefficient of restitution between the block and the plate is $e = 0.75$. Also, find the maximum compression of the spring due to impact. The spring has an unstretched length of 600 mm. (7 marks)

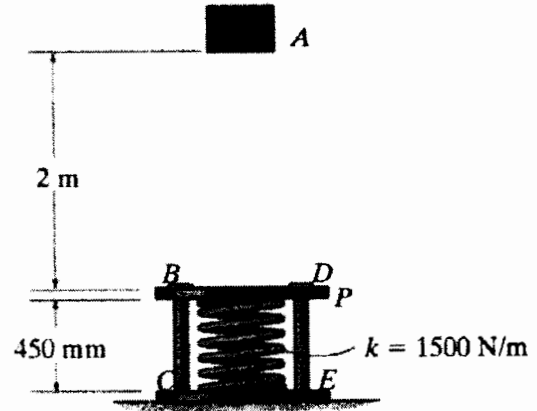

Kinematics of Particles

Particle Rectilinear Motion

| | |
|---|---|
| a is not constant ($a = a(t)$) | a is a constant ($a = a_c$) |
| $a = \frac{dv}{dt}, v = \frac{ds}{dt}, ads = vdv$ | $v = v_o + a_c t, s = s_o + v_o t + \frac{1}{2} a_c t^2$ $v^2 = v_o^2 + 2a(s - s_o)$ |

Particle Curvilinear Motion

| | | | |
|----------------------------|------------------|----------------------------|--|
| x, y, z coordinates | | n, t, b coordinates | |
| $v_x = \dot{x}$ | $a_x = \ddot{x}$ | $v = \dot{s}$ | $a_t = \dot{v} = v \frac{dv}{ds}$ |
| $v_y = \dot{y}$ | $a_y = \ddot{y}$ | | $a_n = \frac{v^2}{\rho}, \rho = \frac{[1 + (dy/dx)^2]^{3/2}}{ d^2y/dx^2 }$ |
| $v_z = \dot{z}$ | $a_z = \ddot{z}$ | | |

| | |
|--|--|
| r, θ, z coordinates | |
| $v_r = \dot{r}, v_\theta = r\dot{\theta}, v_z = \dot{z}$ | $a_r = \ddot{r} - r\dot{\theta}^2, a_\theta = r\ddot{\theta} + 2\dot{r}\dot{\theta}, a_z = \ddot{z}$ |

Kinetics of Particles

Equations of Motion: $\sum \vec{F} = m\vec{a}$

Principle of Work and Energy: $T_1 + \sum U_{1-2} = T_2$

Kinetic Energy: $T = \frac{1}{2}mv^2$

Work

| | | |
|--|--|---|
| $U_F = \int F \cos \theta ds$ | $U_{F_c} = F_c \cos \theta (S_2 - S_1) = F_c \cos \theta \Delta S$ (constant force) | |
| Work done by weight $U_w = -W \Delta y$ | Work done by spring $U_s = -\left(\frac{1}{2}kS_2^2 - \frac{1}{2}kS_1^2\right)$ | Work done by couple moment $U_M = M \Delta \theta$ |

Conservation of Energy Theorem: $T_1 + V_1 = T_2 + V_2$

Potential Energy: $V = V_g + V_e, V_g = \pm Wy, V_e = \frac{1}{2}kS^2$

Power and Efficiency: $P = \frac{dU}{dt} = \vec{F} \cdot \vec{v}, \epsilon = \frac{P_{out}}{P_{in}} = \frac{U_{out}}{U_{in}}$

Impulse and Momentum:

| | |
|--|--|
| $mV_1 + \sum \int F dt = mV_2$ | $\sum (\text{syst. } mV)_1 = \sum (\text{syst. } mV)_2$ $\sum (\text{syst. } H)_1 = \sum (\text{syst. } H)_2$ |
| $(H_o)_1 + \sum \int M_o dt = (H_o)_2$ Where $H_o = (d)(mv)$; d = moment arm | $e = \frac{(v_B)_2 - (v_A)_2}{(v_A)_1 - (v_B)_1}$ |