



คย ๑ / ๒๕๖๖

เลขที่ห้องสอบ

มหาวิทยาลัยเทคโนโลยีพระจอมเกล้าธนบุรี  
ข้อสอบกลางภาคการศึกษาที่ 1/2560

วันศุกร์ที่ 29 กันยายน 2560

เวลา 13.00 -16.00 น.

วิชา CPE 223 Digital Electronics and Logic Design

น.ศ. วศ.คอมพิวเตอร์

คำสั่ง

1. ข้อสอบมีทั้งหมด 11 ข้อ จำนวน 10 แผ่น (รวมแผ่นนี้) คะแนนรวม 45 คะแนน
2. ให้ น.ศ. ทำข้อสอบทุกข้อลงในช่องว่างที่เตรียมไว้ให้ ในตัวข้อสอบชุดนี้
3. ไม่อนุญาต ให้ใช้เครื่องคำนวณ
4. ไม่อนุญาต ให้นำเอกสารใดๆ เข้าห้องสอบ
5. เขียนชื่อ และ รหัสประจำตัว ลงในปกหน้าฉบับนี้

ผศ.สนั่น สระแก้ว

ผู้ออกข้อสอบ

0-2470-9083

ข้อสอบนี้ได้ผ่านการประเมินจากภาควิชาวิศวกรรมคอมพิวเตอร์แล้ว

รศ.ดร.พีรพล ศิริพงษ์วุฒิกกร  
ประธานหลักสูตร

ข้อ	1	2	3	4	5	6	7	8	9	10	11	รวม
คะแนนเต็ม	4	4	4	4	4	6	2	4	4	5	4	45
คะแนนที่ได้												

ชื่อ ..... รหัสประจำตัว.....

1. Convert the following numbers to the base specified:

(4 points)

a)  $(176.34)_8 = ( \quad )_2$

b)  $(236.3125)_{10} = ( \quad )_{16}$

c)  $(177.25)_{10} = ( \quad )_4$

d)  $(7EC.7)_{16} = ( \quad )_{10}$

2. Perform the 8-bit subtraction using 2's complement addition. Determine whether there exists an overflow. (4 points)

	<b>Subtraction</b>	<b>2's complement addition</b>	<b>Overflow?</b>
a)	$\begin{array}{r} 01001000 \\ - 11111001 \\ \hline \end{array}$		
b)	$\begin{array}{r} 01110111 \\ - 10000010 \\ \hline \end{array}$		

3. Simplify the following Boolean expressions using Boolean algebra.

(4 points)

a)  $F(x, y, z) = xyz + x\bar{y}z + \bar{x}$

b)  $F(A, B, C) = \overline{ABC(A + B + C)}$

4. Simplify the circuit using Boolean algebra. Sketch the simplified one.

(4 points)

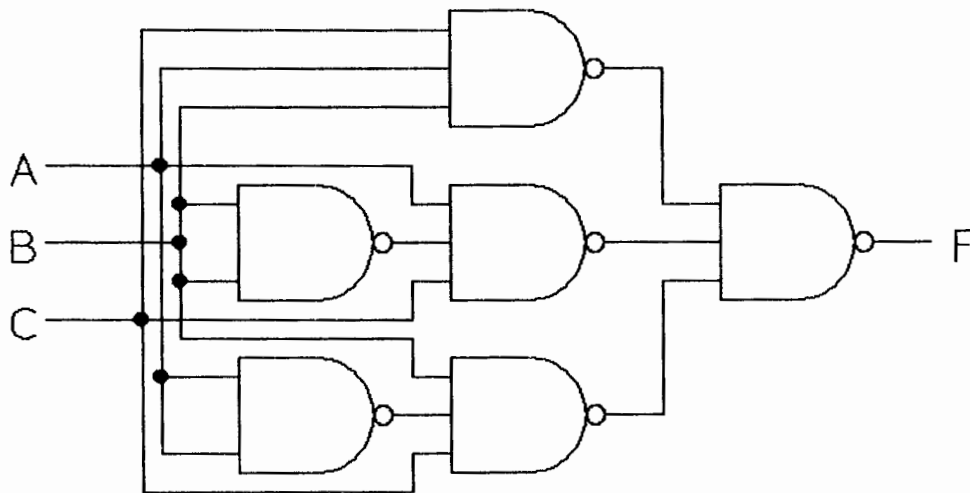

5. Find all the prime implicants for the following Boolean functions, and determine which are essential: (4 points)

a)  $F(W, X, Y, Z) = \Sigma(1, 3, 4, 5, 10, 11, 12, 13, 14, 15)$

b)  $F(A, B, C, D) = (\bar{A} + B + C)(A + B + D)(A + \bar{B} + \bar{C})$

6. Using K-map to minimize the following Boolean expressions and implement a circuit with multiple outputs  $F_1$  and  $F_2$ . How many AND-OR-INVERTER gates? (6 points)

$$F_1(w,x,y,z) = \sum(2, 3, 6, 7, 12, 13, 14)$$

$$F_2(w,x,y,z) = \sum(1, 3, 4, 5, 6, 7, 9, 11, 12, 13, 14)$$

7. Show that the following circuit is equivalent to the XOR gate by using Boolean identities.  
Given

$$A \oplus B = \bar{A}B + A\bar{B}$$

(2 points)

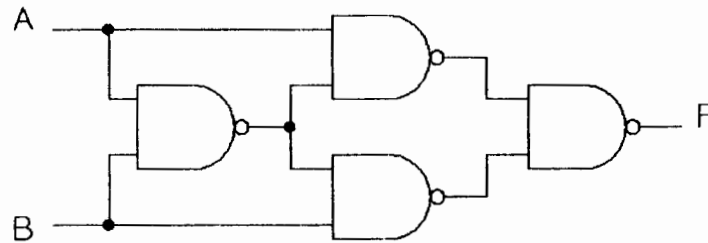

8. Design a car alarm circuit used to detect certain undesirable conditions. There are five switches used to indicate the status of the front door by passenger's and driver's seats(D1,D2), the ignition(G), seat belt(B), and the headlights(L). The alarm(A) will be activated whenever either of the following conditions exists:

- The headlights are ON ( $L=1$ ) while the ignition is OFF( $G=0$ ),
- Either doors is open( $D1=1$  or  $D2=1$ , or both) while the ignition is ON( $G=1$ ),
- Seatbelt is not fastened( $B=0$ ) while the ignition is ON( $G=1$ ).

Simplify your design to a minimum number of AND-OR-INVERTER gates. Sketch the circuit. (4 points)

9. Construct a truth table for the Boolean function  $F(x, y, z) = xy + xz + \bar{y}z$ . Implement the circuit using a 2-to-1 multiplexer and other necessary gates. (4 points)

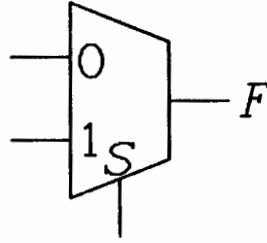

10. Given a sequential circuit with a D flip-flop, one inputs, x; and one output z. List the state table for the sequential circuit and draw the corresponding state diagram (Similar to the In-class exercise on Sept. 20,2017). (5 points)

Fill in state table:

P.S.	Input	Output	N.S.
y	x	z	Q
0	0		
0	1		
1	0		
1	1		

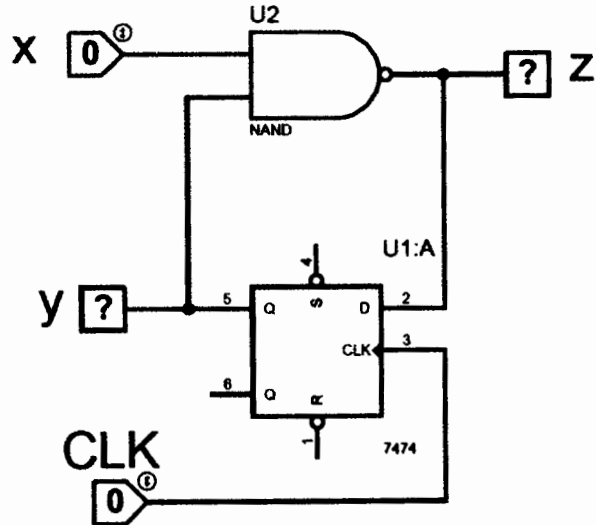

Draw state diagram:



11. Construct a truth table for the Boolean function  $F(A, B, C, D) = \bar{A}B + A\bar{B}C + \bar{B}CD + AC\bar{D}$ .  
 Implement the circuit using two 3-to-8 decoder and other necessary gates. (4 points)

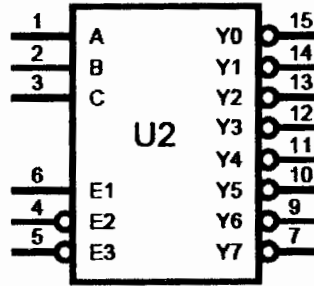
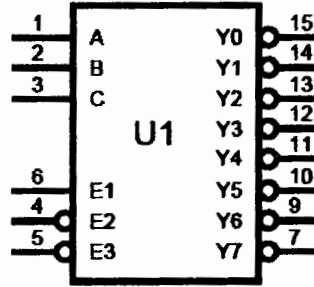

## Supplemental

1.	Law of Identity	$A = A$ $\overline{\overline{A}} = A$
2.	Commutative Law	$A \cdot B = B \cdot A$ $A + B = B + A$
3.	Associative Law	$A \cdot (B \cdot C) = A \cdot B \cdot C$ $A + (B + C) = A + B + C$
4.	Idempotent Law	$A \cdot A = A$ $A + A = A$
5.	Double Negative Law	$\overline{\overline{A}} = A$
6.	Complementary Law	$A \cdot \overline{A} = 0$ $A + \overline{A} = 1$
7.	Law of Intersection	$A \cdot 1 = A$ $A \cdot 0 = 0$
8.	Law of Union	$A + 1 = 1$ $A + 0 = A$
9.	DeMorgan's Theorem	$\overline{AB} = \overline{A} + \overline{B}$ $\overline{A + B} = \overline{A} \overline{B}$
10.	Distributive Law	$A \cdot (B + C) = (A \cdot B) + (A \cdot C)$ $A + (BC) = (A + B) \cdot (A + C)$
11.	Law of Absorption	$A \cdot (A + B) = A$ $A + (AB) = A$
12.	Law of Common Identities	$A \cdot (\overline{A} + B) = AB$ $A + (\overline{A}B) = A + B$